

# QSFP-DD 400G LR8 10km Optical Transceiver

## RQ-400G-LR8

### 1.Function Description

QSFP-DD 400G LR8 module are designed for 10 km optical communication applications, and it is compliant to IEEE 802.3cn for 400GE Ethernet. This module contains 8-lane optical transmitter, 8-lane optical receiver and module management block including 2 wire serial interfaces. The optical signals are multiplexed to a single-mode fiber through an industry standard LC connector. A block diagram is shown in Figure 1-1.

Figure 1-1 Transceiver block diagram

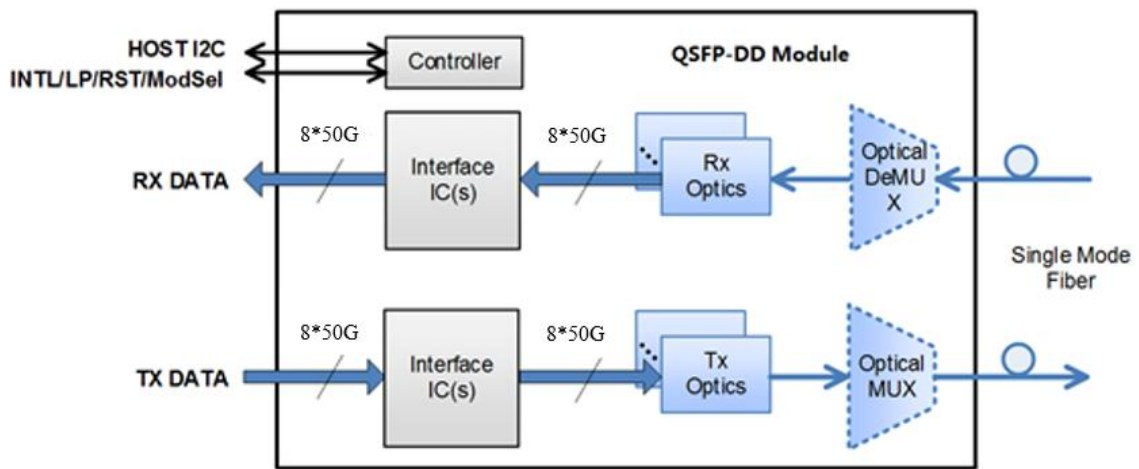

### 2. Pin Descriptions

Figure 2-1 MSA compliant connector

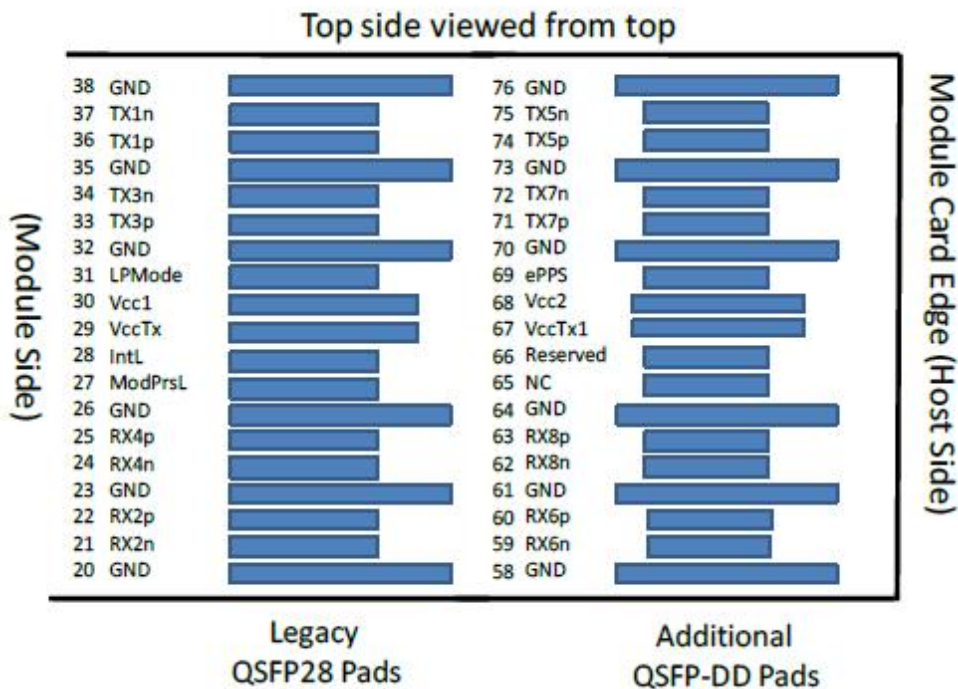

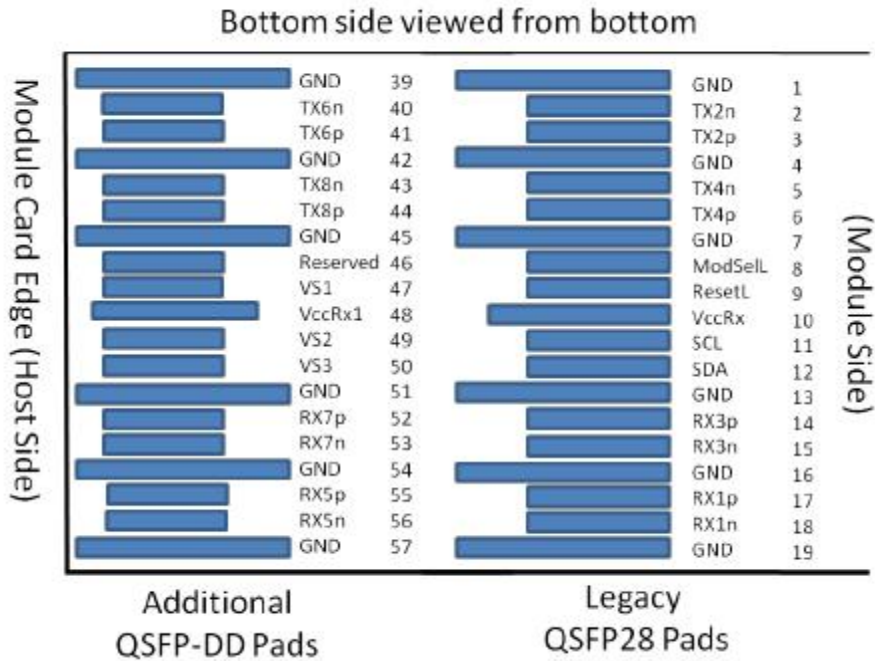

Pin	Symbol	Description	Notes
1	GND	Ground	1
2	Tx2n	Transmitter Inverted Data Input	
3	Tx2p	Transmitter Non-Inverted Data Input	
4	GND	Ground	1
5	Tx4n	Transmitter Inverted Data Input	
6	Tx4p	Transmitter Non-Inverted Data Input	
7	GND	Ground	1
8	ModSelL	Module Select	
9	ResetL	Module Reset	
10	VccRx	+3.3 V Power Supply Receiver	2
11	SCL	2-wire serial interface clock	
12	SDA	2-wire serial interface data	
13	GND	Ground	1
14	Rx3p	Receiver Non-Inverted Data Output	
15	Rx3n	Receiver Inverted Data Output	
16	GND	Ground	1
17	Rx1p	Receiver Non-Inverted Data Output	
18	Rx1n	Receiver Inverted Data Output	
19	GND	Ground	1
20	GND	Ground	1
21	Rx2n	Receiver Inverted Data Output	
22	Rx2p	Receiver Non-Inverted Data Output	
23	GND	Ground	1
24	Rx4n	Receiver Inverted Data Output	
25	Rx4p	Receiver Non-Inverted Data Output	

Pin	Symbol	Description	Notes
26	GND	Ground	1
27	ModPrsL	Module Present	
28	IntL	Interrupt	
29	VccTx	+3.3 V Power supply transmitter	2
30	Vcc1	+3.3 V Power supply	2
31	LPMODE	Low Power mode	
32	GND	Ground	1
33	Tx3p	Transmitter Non-Inverted Data Input	
34	Tx3n	Transmitter Inverted Data Input	
35	GND	Ground	1
36	Tx1p	Transmitter Non-Inverted Data Input	
37	Tx1n	Transmitter Inverted Data Input	
38	GND	Ground	1
39	GND	Ground	1
40	Tx6n	Transmitter Inverted Data Input	
41	Tx6p	Transmitter Non-Inverted Data Input	
42	GND	Ground	1
43	Tx8n	Transmitter Inverted Data Input	
44	Tx8p	Transmitter Non-Inverted Data Input	
45	GND	Ground	1
46	Reserved	For future use	3
47	VS1	Module Vendor Specific 1	3
48	VccRx1	3.3 V Power Supply	2
49	VS2	Module Vendor Specific 2	3
50	VS3	Module Vendor Specific 3	3
51	GND	Ground	1
52	Rx7p	Receiver Non-Inverted Data Output	
53	Rx7n	Receiver Inverted Data Output	
54	GND	Ground	1
55	Rx5p	Receiver Non-Inverted Data Output	
56	Rx5n	Receiver Inverted Data Output	
57	GND	Ground	1
58	GND	Ground	1
59	Rx6n	Receiver Inverted Data Output	
60	Rx6p	Receiver Non-Inverted Data Output	
61	GND	Ground	1
62	Rx8n	Receiver Inverted Data Output	
63	Rx8p	Receiver Non-Inverted Data Output	
64	GND	Ground	1
65	NC	No Connect	3
66	Reserved	For future use	3

Pin	Symbol	Description	Notes
67	VccTx1	3.3 V Power Supply	2
68	Vcc2	3.3 V Power Supply	2
69	ePPS	Precision Time Protocol (PTP) reference clock input. It is not used.	3
70	GND	Ground	1
71	Tx7p	Transmitter Non-Inverted Data Input	
72	Tx7n	Transmitter Inverted Data Input	
73	GND	Ground	1
74	Tx5p	Transmitter Non-Inverted Data Input	
75	Tx5n	Transmitter Inverted Data Input	
76	GND	Ground	1

**Note:**

1. QSFP-DD uses common ground (GND) for all signals and supply (power). All are comon within the QSFP-DD module and all module voltages are referenced to this po-te-nial unless otherwise noted. Connect these directly to the host board signal-common ground plane.
2. VccRx, VccRx1, Vcc1, Vcc2, VccTx and VccTx1 shall be applied concurrently.Requirements defined for the host side of the Host Card Edge Connector. VccRx, VccRx1, Vcc1, Vcc2, VccTx and VccTx1 may be internally connected within the module in any combination. The connector Vcc pins are each rated for a maximum current of 1000 mA.
3. All Vendor Specific, Reserved and No Connect pins may be terminated with 50ohms to ground on the host. Pad 65 (No Connect) shall be left unconnected within the module. Vendor specific and Reserved pads shall have an impedance to GND that is greater than 10K ohms and less than 100pF.

### 3. Absolute Maximum Ratings

It has to be noted that the operation in excess of any individual absolute maximum ratings might cause permanent damage to this module.

Parameter	Symbol	Min	Typ	Max	Unit	Notes
Maximum supply voltage	Vcc	-0.5	3.3	3.6	V	
Storage temperature	Ts	-40		85	°C	
Relative humidity	RH	10		85	%	Non-condensing
Damage threshold, each lane	THd	6.3			dBm	

### 4. Operating Environments

Electrical and optical characteristics below are defined under this operating environment, unless otherwise specified.

Parameter	Symbol	Min	Typ	Max	Unit
Supply voltage	Vcc	3.135	3.3	3.465	V
Case temperature	Top	0		70	°C
Link distance with G.652				10	km

## 5. Electrical Characteristics

Parameter	Symbol	Min	Typ	Max	Unit	Notes
Power dissipation			13.4	14.5	W	
Supply current	Icc			4.625	A	Steady state
<b>400GAUI-8 Electrical Characteristics</b>						
<b>Transmitter</b>						
Signaling rate, each lane			26.5625		GBd	PAM4
Differential voltage pk-pk	Vin, pp			880	mV	
Common mode voltage	Vcm	-0.3		2.8	V	
Common mode noise	RMS			17.5	mV	
Differential termination resistance mismatch				10	%	
Transition time	Trise/Tfall	12			ps	20%~80%
Eye width at 10 <sup>-6</sup> probability	EW6	0.2			UI	
Eye height at at 10 <sup>-6</sup> probability	EH6	32			mV	
Eye linearity		0.85				
<b>Receiver</b>						
Signaling rate, each lane			26.5625		GBd	PAM4
Differential voltage pk-pk	Vout, pp			900	mV	
Transition time	Trise/Tfall	9.5			ps	20%~80%
Near-end eye width at 10 <sup>-6</sup> probability	EW6	0.265			UI	
Near-end eye height at 10 <sup>-6</sup> probability	EH6	70			mV	
Far-end eye width at 10 <sup>-6</sup> probability	EW6	0.2			UI	
Far-end eye height at 10 <sup>-6</sup> probability	EH6	30			mV	
Near-end eye linearity		0.85				

**Note:** 400GAUI-8 Electrical Characteristics refers to CEI-56G-VSR-PAM4 of OIF-CEI-04.0.

## 6. Optical Characteristics

**400GBASE-LR8 Operation** (EOL, TOP = 0 to +70°C, VCC = 3.135 to 3.465 Volts)

Parameters	Min	Type	Max	Unit	Notes
<b>Transmitter</b>					
Signaling speed per lane	26.5625 ± 100 ppm			GBd	
Transmit wavelengths	1272.55	1273.54	1274.54	nm	
	1276.89	1277.89	1278.89		
	1281.25	1282.26	1283.27		

Parameters	Min	Type	Max	Unit	Notes
	1285.65	1286.66	1287.68		
	1294.53	1295.56	1296.59		
	1299.02	1300.05	1301.09		
	1303.54	1304.58	1305.63		
	1308.09	1309.14	1310.19		
Total average launch power			13.2	dBm	
Average launch power, each lane	-2.8		5.3	dBm	
Optical modulation amplitude (OMA), each lane	0.2		5.7	dBm	
Extinction ratio (ER)	3.5			dB	
Side-mode suppression ratio (SMSR)	30			dB	
Transmitter and dispersion eye closure for PAM4 (TDECQ), each lane			3.1	dB	
Average launch power of OFF transmitter, each lane (max)			-30	dBm	
RIN <sub>15.6OMA</sub>			-132	dB/Hz	
Optical return loss tolerance			15.6	dB	
Transmitter reflectance			-26	dB	
<b>Receiver</b>					
Signaling speed per lane	26.5625 ± 100 ppm			GBd	
Receive wavelengths	1272.55	1273.54	1274.54	nm	
	1276.89	1277.89	1278.89		
	1281.25	1282.26	1283.27		
	1285.65	1286.66	1287.68		
	1294.53	1295.56	1296.59		
	1299.02	1300.05	1301.09		
	1303.54	1304.58	1305.63		
	1308.09	1309.14	1310.19		
Average receiver power, each lane	-9.1		5.3	dBm	
Receiver power, each lane (OMA)			5.7	dBm	
Difference in receive power between any two lanes(OMA)			4.5	dB	
Damage threshold, each lane	6.3			dBm	

Parameters	Min	Type	Max	Unit	Notes
Receiver sensitivity (OMA), each lane			RS	dBm	1
LOS assert	-25.1			dBm	
LOS deassert			-11.1	dBm	
LOS hysteresis	0.5			dB	
Receiver reflectance			-26	dB	

**Note:** RS=max (-6.6, SECQ-8) dBm, BER@2E-4

## 7. EEPROM Definitions

Refer to QSFP-DD Common Management Interface Specification Rev 4.0.

## 8. Digital Diagnostic Monitoring Functions

QSFP-DD 400G LR8 support the I2C-based Diagnostic Monitoring Interface (DMI) defined in document QSFP-DD Common Management Interface Specification Rev 4.0. The host can access real-time performance of transmitter and receiver optical power, temperature, supply voltage and bias current.

Performance Item	Related Bytes	Monitor Error	Notes
Module temperature	14 to 15 at Page low	+/-3°C	1, 2
Module voltage	16 to 17 at Page low	< 5%	2
LD bias current	170 to 185 at Page 11h	< 10%	2
Transmitter optical power	154 to 169 at Page 11h	< 3 dB	2
Receiver optical power	186 to 201 at Page 11h	< 3 dB	2

**Note:**

1. Actual temperature test point is fixed on module case around Laser Array.
2. Full operating temperature range.

## 9. Alarm and Warning Thresholds

QSFP-DD 400G LR8 support alarms function, indicating the values of the preceding basic performance are lower or higher than the thresholds.

Performance Item	Alarm Threshold Bytes	Unit	Low Threshold	High Threshold
Temp alarm	128 to 131 at Page 02	°C	-10	80
Temp warning	132 to 135 at Page 02	°C	0	70
Voltage alarm	136 to 139 at Page 02	V	2.97	3.63
Voltage warning	140 to 143 at Page 02	V	3.135	3.465
TX power alarm	176 to 179 at Page 02	dBm	-4.8	7.3
TX power warning	180 to 183 at Page 02	dBm	-2.8	5.3
RX power alarm	192 to 195 at Page 02	dBm	-12.1	7.3

Performance Item	Alarm Threshold Bytes	Unit	Low Threshold	High Threshold
RX power warning	196 to 199 at Page 02	dBm	-10.1	5.3

## 10.Mechanical Specifications

Figure 10-1 Mechanical dimensions

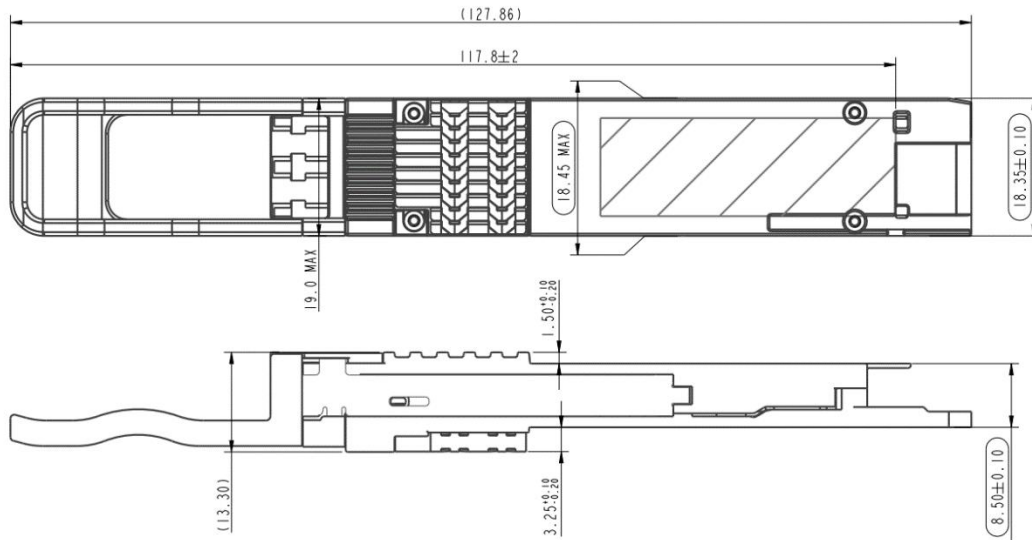

## 11.Ordering Information

Part Number	Description
RQ-400G-LR8	400G, QSFP-DD, 10km, LR8